



## Binocular/Split Mounts

LORD Binocular/Split Mounts are designed for applications involving severe dynamic forces in the static load direction, as well as the rebound direction. Travel is limited in both directions by rubber in compression which provides snubbing.

These mounts are designed as front engine mounts, and accommodate frame racking and twisting while isolating vibration and absorbing shock.

Typical applications for Binocular/Split Mounts include on-highway, off-highway and construction vehicles.

### **Features and Benefits**

- Dynamically effective in all directions
- Prevent mechanical transmission of noise
- Accommodate misalignment and distortion
- High rebound capacity
- Easy to install with common tools
- Standard bolt torque assures proper assembly
- Fail-safe assembly
- Sized for English and Metric bolts
- Long dependable service life
- Economical

## Specifications and Dimensions

Kit Part Number	Sleeve Length (A)		Socket Thickness (B)		Overall Height (C)		Upper Part Thickness (D)		Rated Vertical Load		Deflection @ Rated Load		Vertical Stiffness		Lateral Stiffness	
	in	mm	in	mm	in	mm	in	mm	lb	N	in	mm	lb/in	N/mm	lb/in	N/mm
J-21246-6	2.48	62.9	0.63	16	2.39	60.7	1.34	34	1300	5783	0.101	2.57	13,625	2386	1950	341
J-21246-12	2.48	62.9	0.63	16	2.66	67.6	1.34	34	1000	4448	0.054	1.37	17,647	3090	1400	245
J-21246-13	2.2	55.9	0.75	19	2.39	60.7	0.945	24	1500	6672	0.62	1.58	24,000	4203	3300	578

**Figure 1 – Part Dimensions**

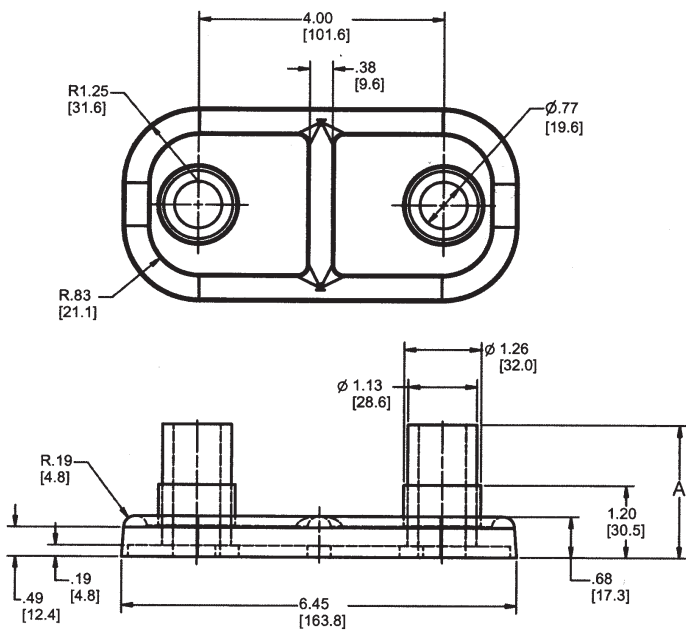

**Figure 2 – Typical Installation (Shown Under No Load)**

