

Two-Piece Mounts

Featuring: CBB and CBC Series
SSB Series
CB-2200 Series

LORD Two-Piece Mounts are designed for applications involving severe dynamic forces in the static load direction, as well as the rebound direction. Travel is limited in both directions by rubber in compression which provides snubbing.

These mounts are designed to support engines, cabs and accessory units, and accommodate frame racking and twisting while isolating vibration and absorbing shock.

Typical applications for Two-Piece Mounts include on-highway, off-highway vehicles, construction and industrial machines.

Features and Benefits

- Dynamically effective in all directions
- Prevent mechanical transmission of noise
- Accommodate misalignment and distortion
- High rebound capacity
- Easy to install with common tools
- Standard bolt torque assures proper assembly
- Top and bottom parts alike, cannot be misassembled
- Fail-safe assembly
- Sized for English and Metric bolts
- Long dependable service life
- Economical

CBB and CBC Series

Table 1 – Specifications and Dimensions

Part Number	See Figure	Maximum Axial Static Load Rating at Deflection ①		Part Dimensions											
				A		B		C		D Ref.		E		F	
		lb at in	N at mm	in	mm	in	mm	in	mm	in	mm	in	mm	in	mm
CBB35-2-7	1 & 2	440 at 0.05	1960 at 1.27	3.50	88.9	0.938	23.8	2.24	56.9	1.48	37.6	1.44	36.6	1.04	26.4
CBB35-2-9	1 & 2	940 at 0.05	4180 at 1.27	3.50	88.9	0.938	23.8	2.25	57.2	1.48	37.6	1.44	36.6	1.04	26.4
CBC35-2-7	3 & 4	500 at 0.05	2225 at 1.27	3.50	88.9	0.938	23.8	2.23	56.6	1.60	40.6	1.44	36.6	1.04	26.4
CBC35-2-9	3 & 4	875 at 0.05	3890 at 1.27	3.50	88.9	0.938	23.3	2.23	56.6	1.60	40.6	1.44	36.6	1.04	26.4
CBB45-2-7	1 & 2	1000 at 0.06	4448 at 1.59	4.50	114.3	1.06	27.1	2.48	63.0	1.76	44.7	1.69	42.9	1.32	33.5
CBB45-2-9	1 & 2	1565 at 0.06	6960 at 1.59	4.50	114.3	1.06	27.1	2.48	63.0	1.76	44.7	1.69	42.9	1.32	33.5
CBC45-2-7	3 & 4	1030 at 0.06	4585 at 1.59	4.50	114.3	1.06	27.1	2.48	63.0	1.94	49.3	1.69	42.9	1.32	33.5
CBC45-2-9	3 & 4	1565 at 0.06	6950 at 1.59	4.50	114.3	1.06	27.1	2.48	63.0	1.94	49.3	1.69	42.9	1.32	33.5
J-8006-10	3 & 4	440 at 0.04	1960 at 0.95	2.50	63.5	0.64	16.3	1.63	41.3	0.81	20.6	0.56	14.2	0.62	15.7
J-8006-66	3 & 4	565 at 0.04	2515 at 0.95	2.50	63.5	0.64	16.3	1.50	38.1	1.19	30.2	0.94	23.9	0.62	15.7

All metal parts are made of low carbon steel.
Mounts and washers only supplied by LORD.

① These loads are for on-highway and general industrial applications. For off-highway, use 90% of the load shown.

Table 2 – Specifications and Dimensions

Part Number	Part Dimensions ②										Recommended Bolt Information*			
	G		H		S _D ±0.015		R		T		Size		Grade or Class	
	in	mm	in	mm	in	mm	in	mm	in	mm	English	Metric	SAE J429	SAE J1199
CBB35-2-7	0.94	23.9	2.88	73.2	2.26	57.5	—	—	1.00	25.4	7/8	M20	8	10.9
CBB35-2-9	0.94	23.9	2.88	73.2	2.26	57.5	—	—	1.00	25.4	7/8	M20	8	10.9
CBC35-2-7	0.94	23.9	2.88	73.2	2.26	57.5	0.12	3.1	1.00	25.4	7/8	M20	8	10.9
CBC35-2-9	0.94	23.9	2.88	73.2	2.26	57.5	0.12	3.1	1.00	25.4	7/8	M20	8	10.9
CBB45-2-7	1.19	30.2	3.38	85.8	2.53	64.3	—	—	1.00	25.4	1	M24	8	10.9
CBB45-2-9	1.19	30.2	3.38	85.8	2.53	64.3	—	—	1.00	25.4	1	M24	8	10.9
CBC45-2-7	1.19	30.2	3.38	85.8	2.53	64.3	0.12	3.1	1.00	25.4	1	M24	8	10.9
CBC45-2-9	1.19	30.2	3.38	85.8	2.53	64.3	0.12	3.1	1.00	25.4	1	M24	8	10.9
J-8006-10	0.47	11.9	1.12	28.5	1.65	41.9	0.03	0.76	0.18	4.6	5/8	M16	2	9.8
J-8006-66	0.50	12.7	1.88	47.8	1.53	38.9	0.06	1.5	0.88	22.4	5/8	M16	8	10.9

② Installed dimensions are under no load.

* For tightening torque information, refer to Tightening Torque Charts section.

Figure 1 – Part Dimensions - CBB Series

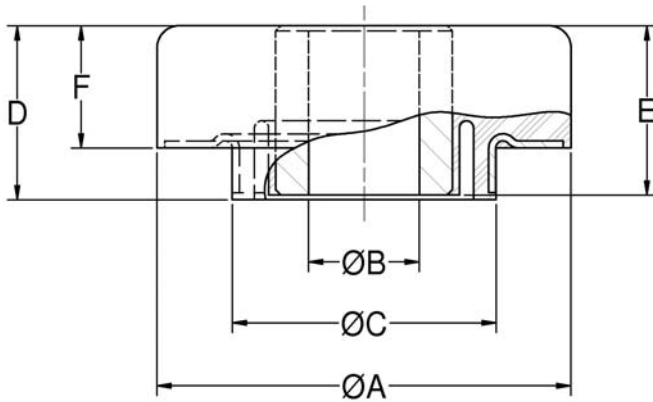

Figure 2 – Installation View - CBB Series (Shown Under No Load)

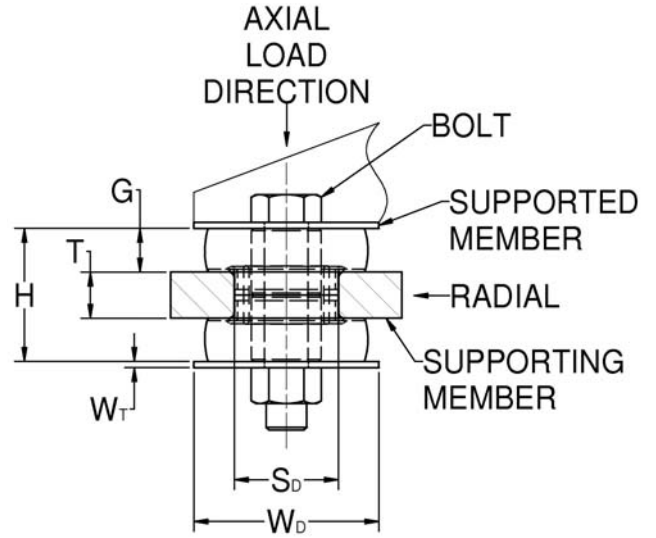

Figure 3 – Part Dimensions - CBC and J-8006 Series

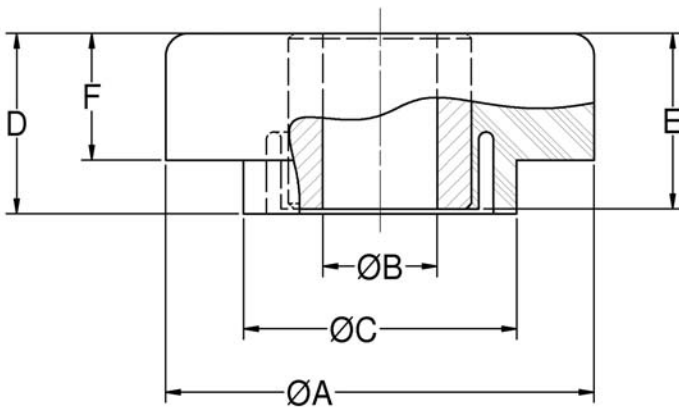

Figure 4 – Installation View - CBC and J-8006 Series (Shown Under No Load)

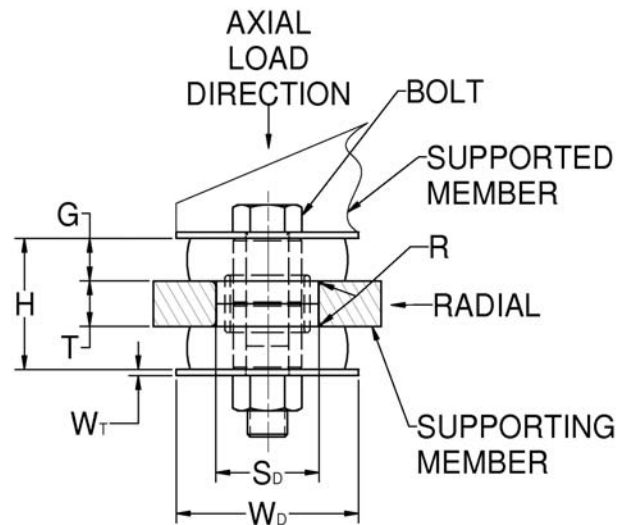

Table 3 – Washer Part Numbers and Dimensions

Part Number	Washer Part Number	W _D		W _T		I.D.	
		in	mm	in	mm	in	mm
CBB35-2-7	J-2049-72	4.00	101.6	0.134	3.4	0.95	24.1
CBB35-2-9	J-2049-72	4.00	101.6	0.134	3.4	0.95	24.1
CBC35-2-7	J-2049-72	4.00	101.6	0.134	3.4	0.95	24.1
CBC35-2-9	J-2049-72	4.00	101.6	0.134	3.4	0.95	24.1
CBB45-2-7	J-2049-73	5.00	127.0	0.134	3.4	1.07	27.2
CBB45-2-9	J-2049-73	5.00	127.0	0.134	3.4	1.07	27.2
CBC45-2-7	J-2049-73	5.00	127.0	0.134	3.4	1.07	27.2
CBC45-2-9	J-2049-73	5.00	127.0	0.134	3.4	1.07	27.2
J-8006-10	J-2049-68	2.88	73.2	0.125	3.2	0.66	16.8
J-8006-66	J-2049-68	2.88	73.2	0.125	3.2	0.66	16.8

SSB Series

Table 1 – Specifications and Dimensions

Part Number			Maximum Axial Static Load Rating at Deflection ①		Axial Spring Rate		Radial Spring Rate	
Kit	Mounting P/N	Spacer P/N	lb at in	N at mm	lb/in	N/mm	lb/in	N/mm
SSB20-1000-2	J-7401-27	Y-30100-7-1	185 at 0.035	825 at 0.90	4970	890	560	97
SSB20-1000-4	J-7401-29	Y-30100-7-1	300 at 0.040	1335 at 1.02	8120	1430	910	160
SSB26-1000-1	J-3049-67	Y-30100-7-1	400 at 0.035	1780 at 0.90	11,000	1930	1370	240
SSB26-1000-5	J-3049-70	Y-30100-7-1	685 at 0.040	3050 at 1.02	17,900	3215	2230	392
SSB33-1000-2	SSB33-1001-2	Y-32190-1-1	625 at 0.045	2780 at 1.15	15,200	2650	2220	385
SSB33-1000-4	SSB33-1001-4	Y-32190-1-1	1125 at 0.03	5005 at 0.76	37,500	6566	3890	675

① These loads are for on-highway and general industrial applications. For off-highway, use 80% of the load shown.

Table 2 – Specifications and Dimensions

Part Number			Part Dimensions															
			A		B		C		D		E		F		H		I	
Kit	Mounting P/N	Spacer P/N	in	mm	in	mm	in	mm	in	mm	in	mm	in	mm	in	mm	in	mm
SSB20-1000-2	J-7401-27	Y-30100-7-1	2.22	56.4	2.00	50.8	0.81	20.6	0.125	3.2	1.81	46.0	1.38	3.50	0.31	7.9	0.510	12.9
SSB20-1000-4	J-7401-29	Y-30100-7-1	2.22	56.4	2.00	50.8	0.81	20.6	0.125	3.2	1.81	46.0	1.38	3.50	0.31	7.9	0.510	12.9
SSB26-1000-1	J-3049-67	Y-30100-7-1	2.62	66.5	—	—	0.81	20.6	0.125	3.2	1.81	46.0	1.38	35.0	0.31	7.9	0.510	12.9
SSB26-1000-5	J-3049-70	Y30100-7-1	2.62	66.5	—	—	0.81	20.6	0.125	3.2	1.81	46.0	1.38	35.0	0.31	7.9	0.510	12.9
SSB33-1000-2	SSB33-1001-2	Y-32190-1-1	3.24	82.3	3.21	81.5	0.81	20.6	0.125	3.2	1.81	46.0	1.84	46.7	0.29	7.4	0.765	19.4
SSB33-1000-4	SSB33-1001-4	Y-32190-1-1	3.24	82.3	3.21	81.5	0.81	20.6	0.125	3.2	1.81	46.0	1.84	46.7	0.29	7.4	0.765	19.4

Table 3 – Specifications and Dimensions

Part Number			Installation Dimensions							
			K		S _D ±0.015		R		T	
Kit	Mounting P/N	Spacer P/N	in	mm	in	mm	in by degree	mm by degree	in	mm
SSB20-1000-2	J-7401-27	Y-30100-7-1	2.06	52.3	1.40	35.6	0.07 by 45	1.8 by 45	0.625	15.9
SSB20-1000-4	J-7401-29	Y-30100-7-1	2.06	52.3	1.40	35.6	0.07 by 45	1.8 by 45	0.625	15.9
SSB26-1000-1	J-3049-67	Y-30100-7-1	2.06	52.3	1.40	35.6	0.07 by 45	1.8 by 45	0.625	15.9
SSB26-1000-5	J-3049-70	Y-30100-7-1	2.06	52.3	1.40	35.6	0.07 by 45	1.8 by 45	0.625	15.9
SSB33-1000-2	SSB33-1001-2	Y-32190-1-1	2.06	52.3	1.87	47.6	—	—	0.625	15.9
SSB33-1000-4	SSB33-1001-4	Y-32190-1-1	2.06	52.3	1.87	47.6	—	—	0.625	15.9

All metal parts are made of low carbon steel.

For applications in severe oil environments, contact LORD. Based on extensive experience, Two-Piece Mounts have been designed to operate in normal fluid, temperature and other environmental conditions such as found in the engine compartment of on- and off-highway applications.

Tolerances: 0.xx = ± 0.03 in (± 0.762 mm)
 0.xxx = ± 0.01 in (± 0.254 mm)
 Angles ± 2°

Figure 1 – Part Dimensions

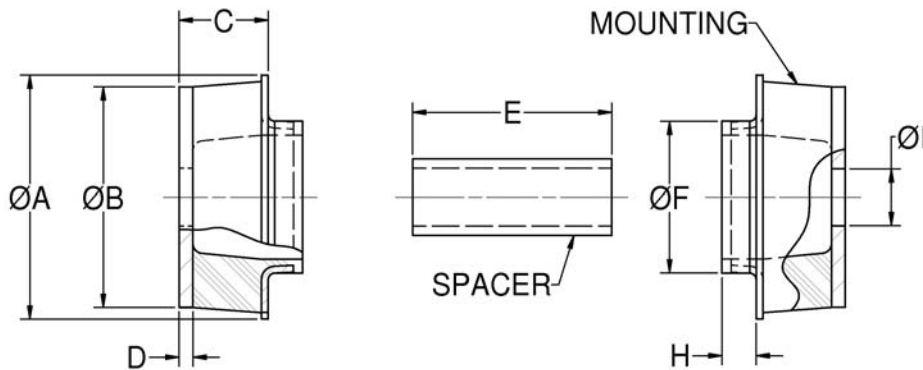

**Figure 2 – Installation View
(Shown Under No Load)**

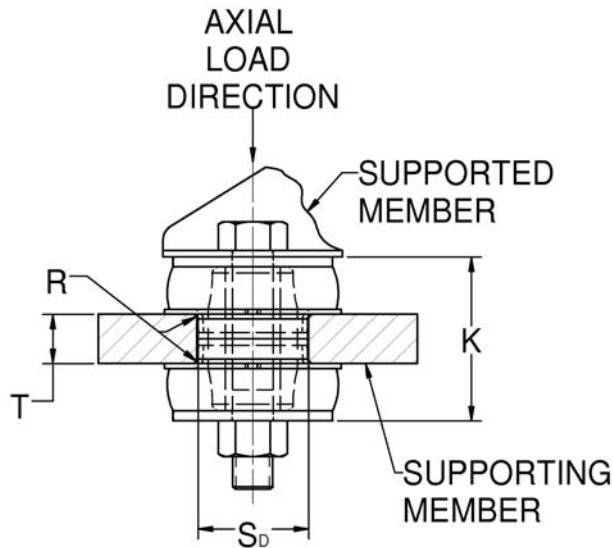

Table 4 – Specifications and Dimensions

Part Number			Recommended Bolt Information*			
			Size		Grade or Class	
Kit	Mounting P/N	Spacer P/N	English	Metric	SAE J429	SAE J1199
SSB20-1000-2	J-7401-27	Y-30100-7-1	1/2	M12	2	5.8
SSB20-1000-4	J-7401-29	Y-30100-7-1	1/2	M12	2	5.8
SSB26-1000-1	J-3049-67	Y-30100-7-1	1/2	M12	2	5.8
SSB26-1000-5	J-3049-70	Y-30100-7-1	1/2	M12	2	5.8
SSB33-1000-2	SSB33-1001-2	Y-32190-1-1	3/4	M18	8	10.9
SSB33-1000-4	SSB33-1001-4	Y-32190-1-1	3/4	M18	8	10.9

* For tightening torque information, refer to Tightening Torque Charts section.

CB-2200 Series

Table 1 – Specifications and Dimensions

Part Number ①	Elastomer ②	Color Code ③	Part Number ①	Elastomer ②	Color Code ③	Maximum Axial Load at Deflection Based on Plate Thickness							
						T - Thick Support Plate (Recommended)				T - Thin Support Plate (Optional)			
						Thickness - T		Load/Deflection ④		Thickness - T		Load/Deflection ④	
						in	mm	lb at in	N at mm	in	mm	lb at in	N at mm
CB-2201-1	NR	R	CB-2201-11	OR	R & W	0.375	9.5	40 at 0.05	178 at 1.3	0.375	9.5	40 at 0.05	178 at 1.3
CB-2201-2	NR	Y	CB-2201-12	OR	Y & W	0.375	9.5	90 at 0.05	400 at 1.3	0.375	9.5	90 at 0.05	400 at 1.3
CB-2201-3	NR	G	CB-2201-13	OR	G & W	0.375	9.5	140 at 0.05	623 at 1.3	0.375	9.5	140 at 0.05	623 at 1.3
CB-2201-4	NR	B	CB-2201-14	OR	B & W	0.375	9.5	250 at 0.05	1112 at 1.3	0.375	9.5	250 at 0.05	1112 at 1.3
—	—	—	CB-2201-15	OR	P & W	0.375	9.5	300 at 0.05	1334 at 1.3	0.375	9.5	300 at 0.05	1334 at 1.3
CB-2202-1	NR	R	CB-2202-11	OR	R & W	0.563	14.3	130 at 0.07	578 at 1.8	0.500	12.7	60 at 0.05	267 at 1.3
CB-2202-2	NR	Y	CB-2202-12	OR	Y & W	0.563	14.3	175 at 0.07	778 at 1.8	0.500	12.7	120 at 0.05	534 at 1.3
CB-2202-3	NR	G	CB-2202-13	OR	G & W	0.563	14.3	240 at 0.07	1068 at 1.8	0.500	12.7	160 at 0.05	712 at 1.3
CB-2202-4	NR	B	CB-2202-14	OR	B & W	0.563	14.3	380 at 0.07	1690 at 1.8	0.500	12.7	260 at 0.05	1157 at 1.3
CB-2202-5	NR	P	CB-2202-15	OR	P & W	0.563	14.3	630 at 0.07	2802 at 1.8	0.500	12.7	380 at 0.05	1690 at 1.3
CB-2203-1	NR	R	—	—	—	0.875	22.2	175 at 0.085	780 at 2.2	0.750	19.1	100 at 0.05	440 at 1.3
—	—	—	CB-2203-12	OR	Y & W	0.875	22.2	300 at 0.085	1330 at 2.2	0.750	19.1	150 at 0.05	670 at 1.3
CB-2203-3	NR	G	CB-2203-13	OR	G & W	0.875	22.2	400 at 0.085	1780 at 2.2	0.750	19.1	225 at 0.05	1000 at 1.3
CB-2203-4	NR	B	CB-2203-14	OR	B & W	0.875	22.2	500 at 0.085	2220 at 2.2	0.750	19.1	325 at 0.05	1450 at 1.3
CB-2203-5	NR	P	CB-2203-15	OR	P & W	0.875	22.2	725 at 0.085	3220 at 2.2	0.750	19.1	450 at 0.05	2000 at 1.3
CB-2204-1	NR	R	CB-2204-11	OR	R & W	1.125	28.6	400 at 0.09	1780 at 2.3	1.000	25.4	200 at 0.05	890 at 1.3
CB-2204-2	NR	Y	CB-2204-12	OR	Y & W	1.125	28.6	550 at 0.09	2450 at 2.3	1.000	25.4	300 at 0.05	1330 at 1.3
CB-2204-3	NR	G	CB-2204-13	OR	G & W	1.125	28.6	700 at 0.09	3110 at 2.3	1.000	25.4	400 at 0.05	1780 at 1.3
CB-2204-4	NR	B	CB-2204-14	OR	B & W	1.125	28.6	850 at 0.09	3780 at 2.3	1.000	25.4	500 at 0.05	2220 at 1.3
CB-2204-5	NR	P	CB-2204-15	OR	P & W	1.125	28.6	1000 at 0.09	4450 at 2.3	1.000	25.4	600 at 0.05	2670 at 1.3
CB-2205-1	NR	R	CB-2205-11	OR	R & W	1.250	31.8	900 at 0.09	4000 at 2.3	1.000	25.4	300 at 0.05	1334 at 1.3
CB-2205-2	NR	Y	CB-2205-12	OR	Y & W	1.250	31.8	1200 at 0.09	5340 at 2.3	1.000	25.4	500 at 0.05	2224 at 1.3
CB-2205-3	NR	G	—	—	—	1.250	31.8	1500 at 0.09	6670 at 2.3	1.000	25.4	700 at 0.05	3114 at 1.3
CB-2205-4	NR	B	CB-2205-14	OR	B & W	1.250	31.8	1800 at 0.09	8010 at 2.3	1.000	25.4	900 at 0.05	4003 at 1.3
CB-2205-5	NR	P	CB-2205-15	OR	P & W	1.250	31.8	2100 at 0.09	9340 at 2.3	1.000	25.4	1100 at 0.05	5338 at 1.3
CB-2205-7	NR	Y & Y	—	OR	Y & Y & W	1.250	31.8	1600 at 0.09	7117 at 2.3	1.000	25.4	775 at 0.05	3447 at 1.3
—	—	—	CB-2205-18	OR	G & G & W	1.250	31.8	2200 at 0.09	9786 at 2.3	1.000	25.4	1000 at 0.05	4448 at 1.3
CB-2205-9	NR	B & B	CB-2205-19	OR	B & B & W	1.250	31.8	2825 at 0.09	12566 at 2.3	1.000	25.4	1425 at 0.05	6339 at 1.3
CB-2205-10	NR	P & P	CB-2205-20	OR	P & P & W	1.250	31.8	3450 at 0.09	15346 at 2.3	1.000	25.4	1800 at 0.05	8007 at 1.3

Mounts only supplied by LORD.

① One P/N contains one top and one bottom mount only.

② NR = Natural Rubber
OR = Oil-Resistant Elastomer - Neoprene

③ Color Codes: R = Red Y = Yellow
G = Green B = Blue
P = Purple W = White

④ These loads are for on-highway and general industrial applications. For off-highway, use 90% of the load shown.

Caution: When using the maximum bolt torque listed a hardened (R_B95) rebound washer and support member should be used. A hardened washer may be placed under the supported member when the supported member is not hardened.

Table 2 – Specifications

Series Number	Recommended Bolt Information*			
	Size		Grade or Class	
	English	Metric	SAE J429	SAE J1199
CB-2201	3/8	M10	5	5.8
CB-2202	1/2	M12	8	10.9
CB-2203	5/8	M16	8	10.9
CB-2204	7/8	M20	8	10.9
CB-2205	1.0	M24	8	10.9

* For tightening torque information, refer to Tightening Torque Charts section.

Table 3 – Washer Specifications

Series Number	Washer Part Number	O.D.		I.D.		Thickness	
		in	mm	in	mm	in	mm
CB-2201	J-2049-89	1.56	39.6	0.391	9.9	0.09	2.3
CB-2202	J-2049-90	2.13	54.1	0.530	13.5	0.134	3.4
CB-2203	J-2049-91	2.81	71.4	0.657	16.7	0.188	4.8
CB-2204	J-2049-92	3.88	98.6	0.938	23.8	0.250	6.4
CB-2205	J-2049-93	5.25	133.4	1.063	27.0	0.375	9.5

Material is SAE 1008-1015 steel zinc plated and chromate treated.

Table 4 – Specifications and Dimensions

Series Number	Part Dimensions														H Reference				Installation Dimensions			
	A		B		C Ref.		D		E		F		G		Thick Support Plate		Thin Support Plate		S _D		R Ref.	
	in	mm	in	mm	in	mm	in	mm	in	mm	in	mm	in	mm	in	mm	in	mm	in	mm	in	mm
CB-2201	1.34/1.28	33.3	0.407/0.396	10.2	0.58	14.7	1.28/1.22	31.8	0.82/0.76	20.1	0.515/0.455	12.3	0.62/0.58	15.2	0.44	11.2	0.44	11.2	0.77/0.73	19.1	0.04	1.0
CB-2202	1.91/1.85	47.8	0.547/0.517	13.5	0.83	21.1	1.97/1.91	49.3	1.33/1.27	33.0	0.81/0.75	19.8	0.845/0.825	21.2	0.69	17.5	0.72	18.3	1.27/1.23	31.8	0.06	1.5
CB-2203	2.58/2.52	64.8	0.672/0.642	16.7	0.97	24.6	2.46/2.40	61.7	1.61/1.55	40.1	0.93/0.87	22.9	0.99/0.95	24.8	0.78	19.8	0.84	21.3	1.52/1.48	38.1	0.09	2.3
CB-2204	3.49/3.43	87.9	0.958/0.938	24.1	1.45	36.8	2.91/2.85	73.0	2.33/2.27	58.4	1.03/0.97	25.4	1.50/1.46	37.6	0.88	22.4	0.94	23.9	2.27/2.23	57.2	0.12	3.0
CB-2205	4.94/4.82	124.0	1.078/1.048	27.0	1.50	38.1	3.41/3.35	85.9	2.58/2.52	64.8	1.28/1.22	31.8	1.52/1.46	37.8	1.06	26.9	1.19	30.2	2.52/2.48	63.5	0.12	3.0

Figure 1 – Part Dimensions

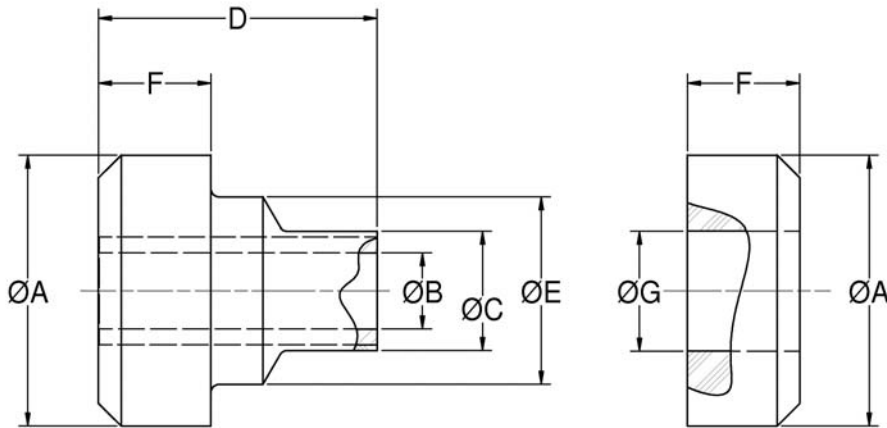

Figure 2 – Installation View (Shown Under No Load)

